

2.5 L-Engine – Digifant Multiport Fuel Injection (MFI)/81kW, code ACU,

from September 1994

Relay location

For relay location and multiple connectors see also section "component locations".

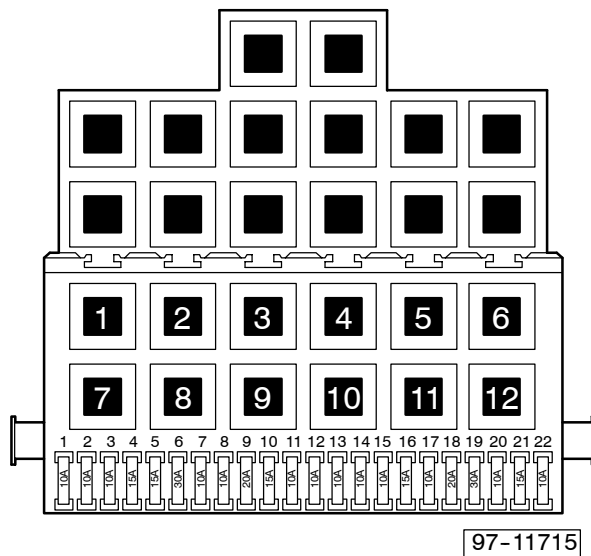

- 2** – Rear Window Wiper/Washer Relay (72)
- 3** – Digifant Engine Control Module (ECM)
Power Supply Relay (30)
- 4** – Load Reduction Relay (18)
- 6** – Emergency Flasher Relay (21)
- 8** – Washer/Wiper Intermittent Relay (19)
- 11** – Dual Horn Relay (53)
- 12** – Fuel Pump (FP) Relay (80)

Note: Number in parentheses indicates production control number stamped on relay housing.

Fuse colors

30A – green
 25A – white
 20A – yellow
 15A – blue
 10A – red

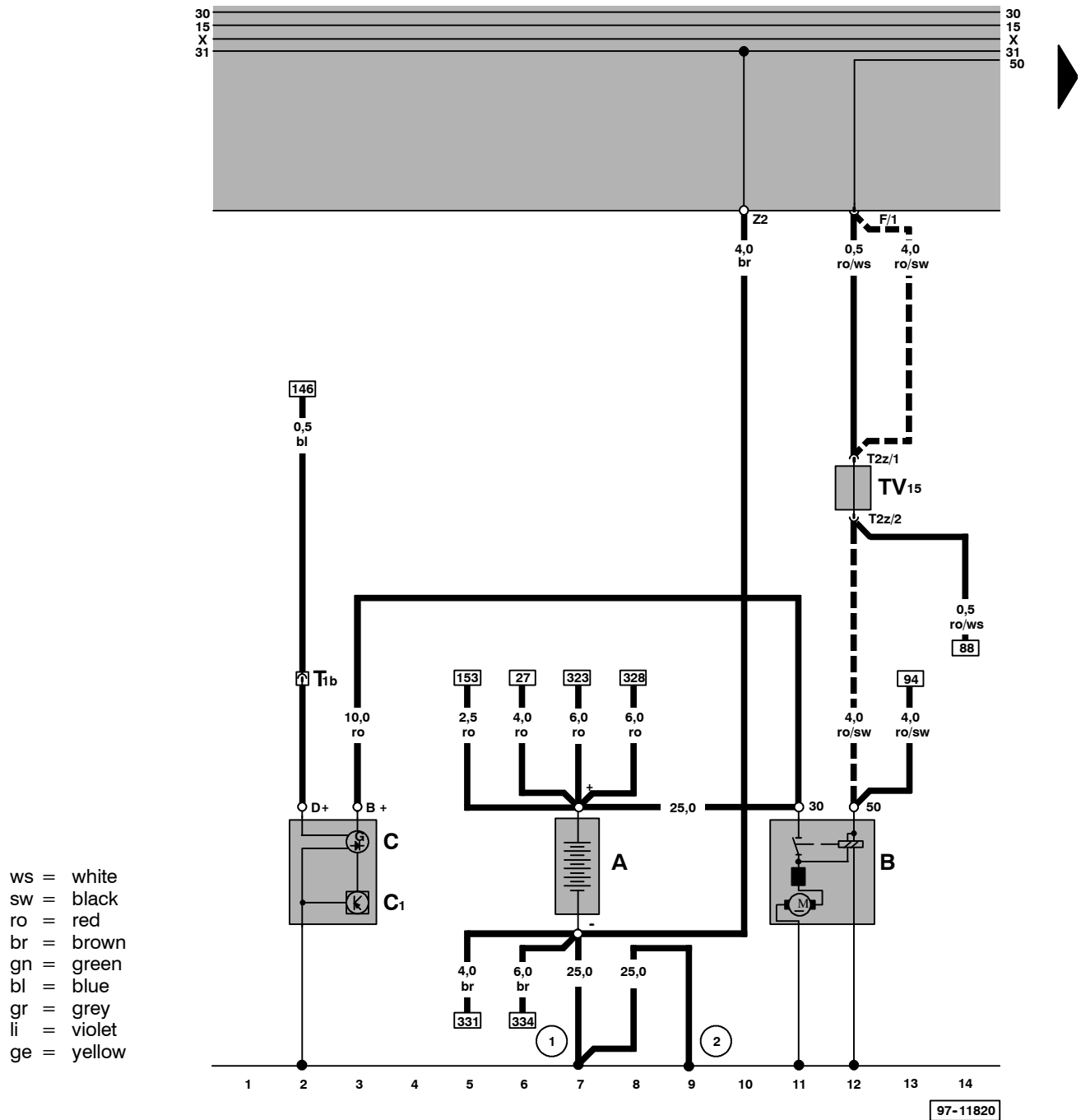

- A – Battery
- B – Starter
- C – Generator (GEN)
- C1 – Voltage Regulator (VR)
- T1b – Single Connector, near starter
- T2z – Double Connector, behind instrument panel ,left
- TV15 – Wire Connector, behind fuse/relay panel (cancelled)
- ① – Ground strap, battery to body
- ② – Ground strap, transmission to body
- – Manual transmission only

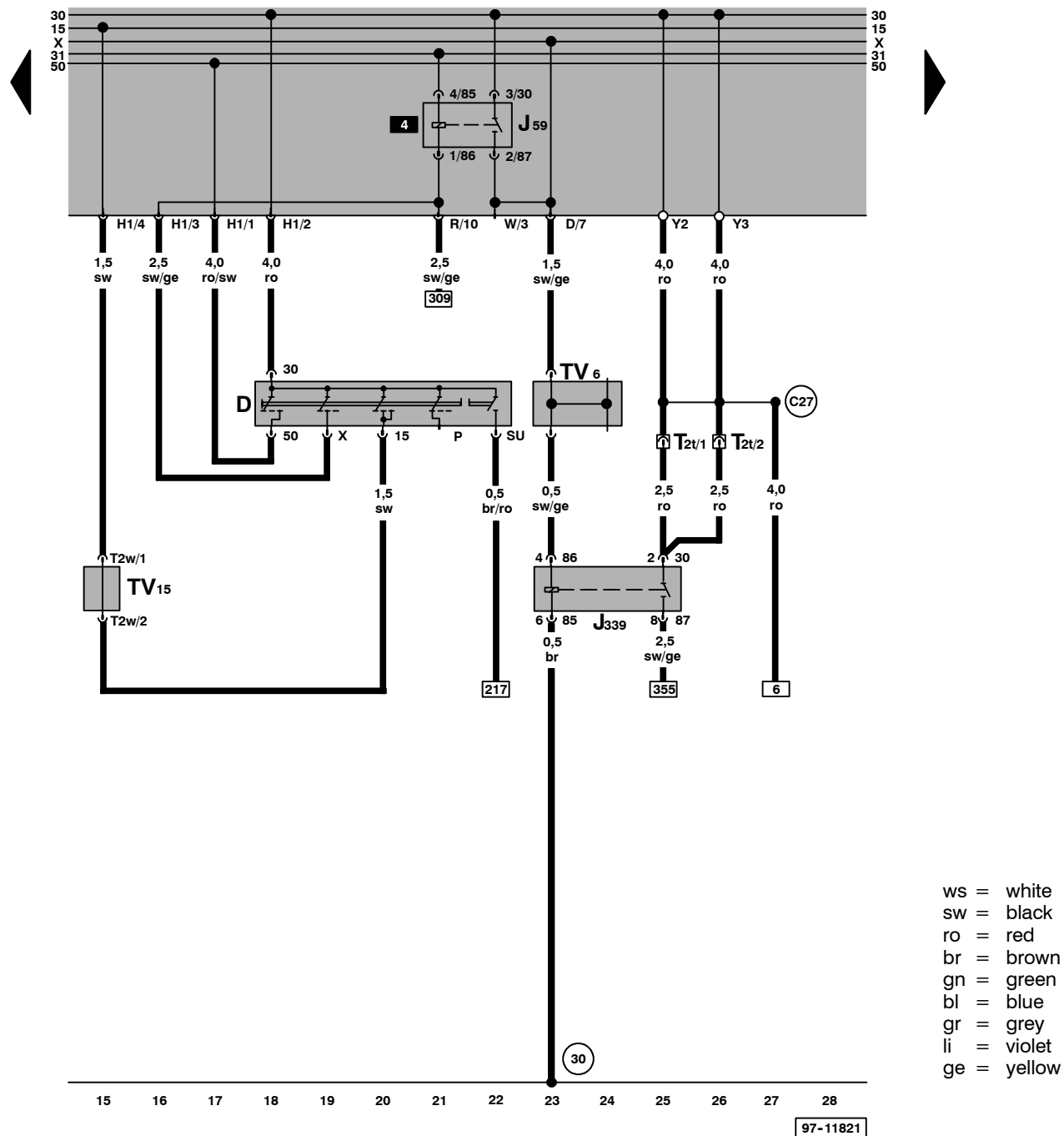

- D – Ignition/Starter Switch
 J59 – Load Reduction Relay
 J339 – Load Reduction Relay II, behind instrument panel, center
 T2t – Double Connector, behind fuse/relay panel
 TV6 – Terminal X Wire Connector, above fuse/relay panel
 TV15 – Wire Connector, behind fuse/relay panel (cancelled)

(30) – Ground connection, –1–, beside fuse/relay panel

(C27) – Plus connection –2– (30), in headlight wiring harness

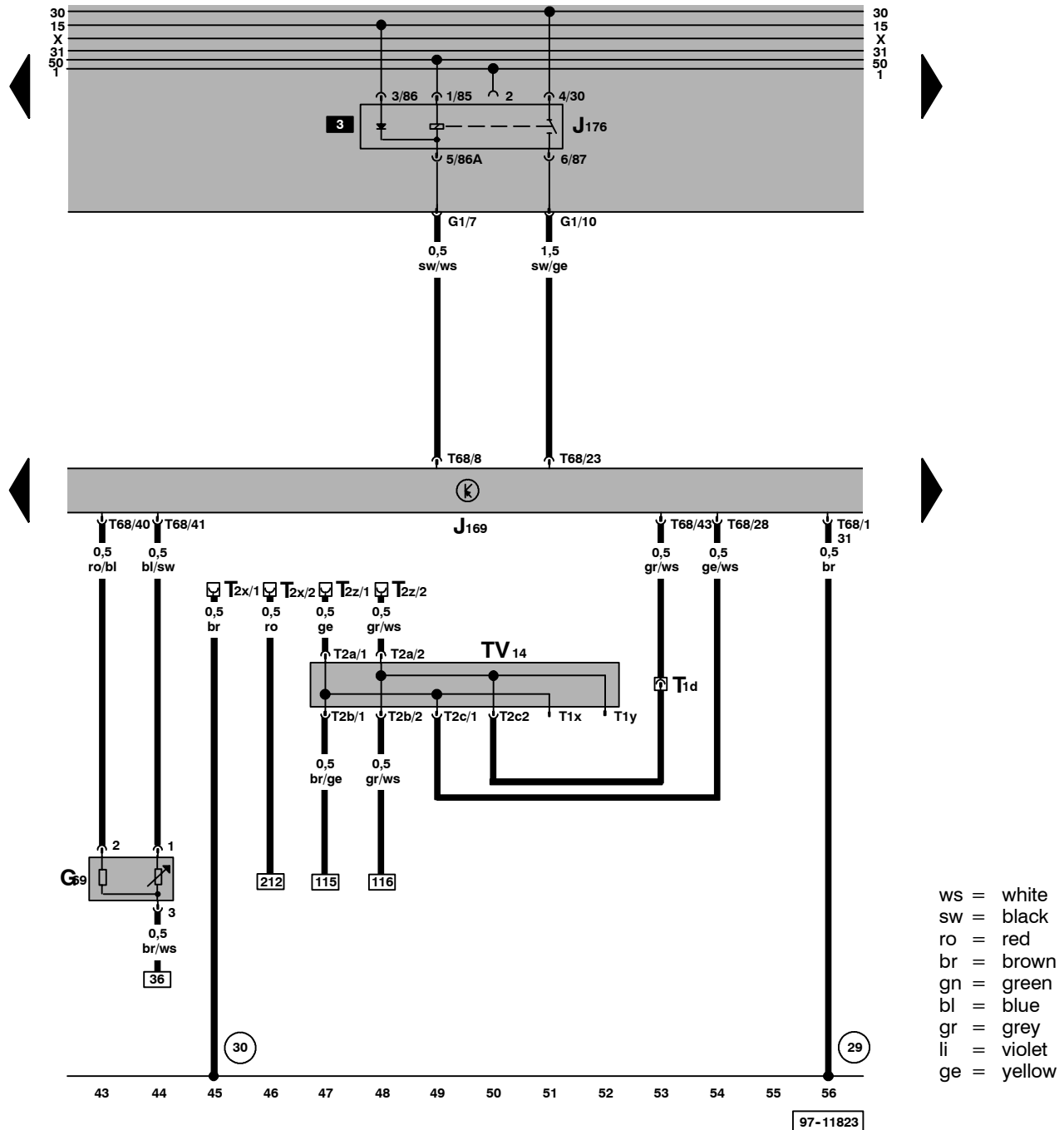

- G69 – Throttle Position (TP) Sensor (00518–2212)
- J169 – Digifant Engine Control Module (ECM), near battery
- J176 – Digifant Engine Control Module (ECM) Power Supply Relay
- T1d – Single Connector, behind fuse relay/panel
- T1x – Single Connector
- T1y – Single Connector
- T2a – Double Connector, above fuse/relay panel
- T2b – Double Connector, above fuse/relay panel
- T2c – Double Connector
- T2x – Double Connector, black, behind instrument panel, center (OBD)
- T2z – Double Connector, white, behind instrument panel, center (OBD)
- T68 – 68-Pin Connector

TV14 – Data Link Connector (DLC) Wire Connector for on-board diagnostic (OBD)

(29) – Ground connection, near battery

(30) – Ground connection, –1–, beside fuse/relay panel

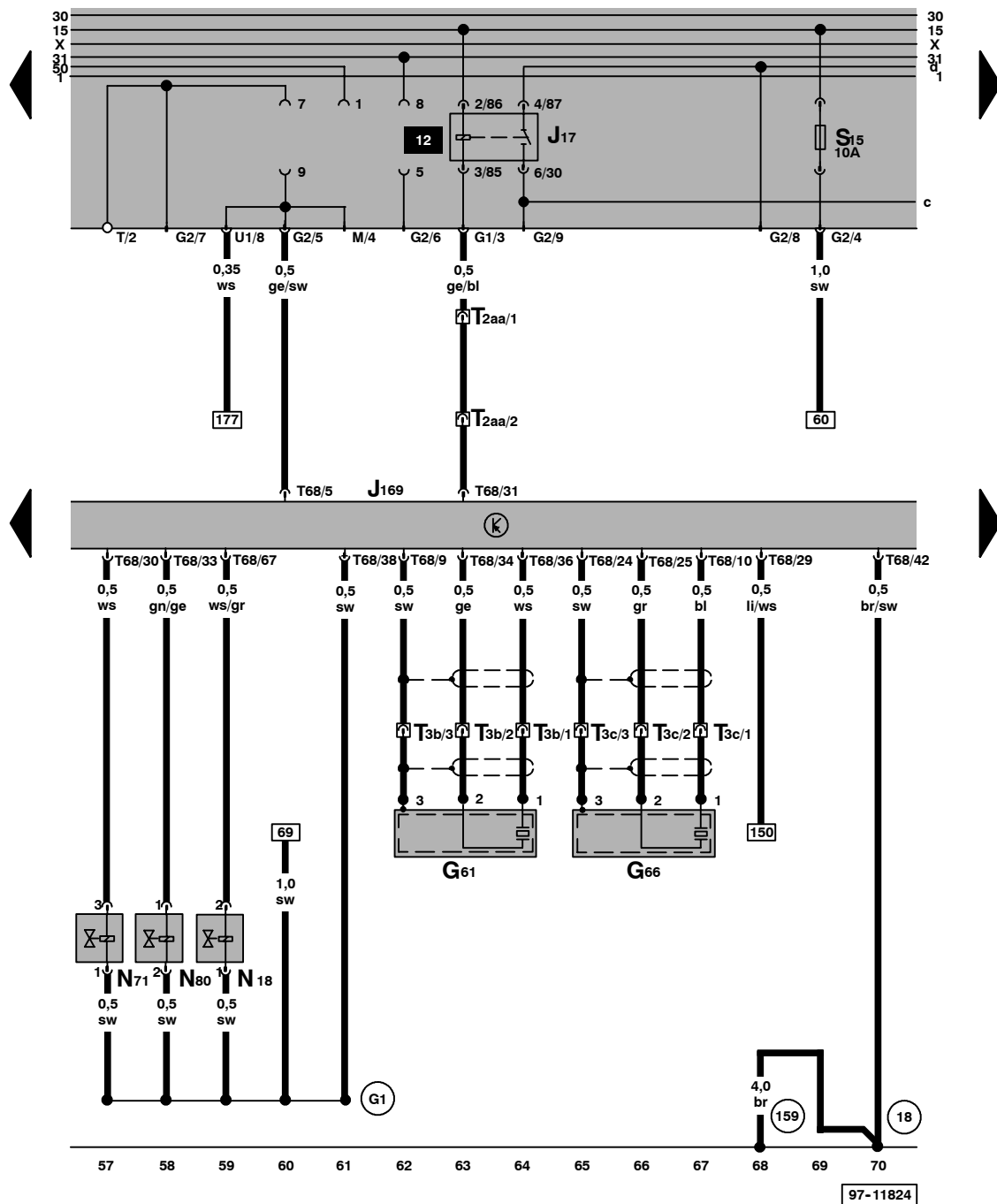

ws = white
 sw = black
 ro = red
 br = brown
 gn = green
 bl = blue
 gr = grey
 li = violet
 ge = yellow

- G61 – Knock Sensor (KS) 1 (00524–2142)
- G66 – Knock Sensor (KS) II (00540–2144)
- J17 – Fuel Pump (FP) Relay
- J169 – Digifant Engine Control Module (ECM), near battery
- N18 – EGR Vacuum Regulator Solenoid Valve
- N71 – Idle Air Control (IAC) Valve
- N80 – Evaporative Emission (EVAP) Canister Purge Regulator Valve
- T2aa – Double Connector (was not used)
- T3b – 3-Pin Connector, near exhaust manifold
- T3c – 3-Pin Connector, near exhaust manifold
- T68 – 68-Pin Connector

(18) – Ground connection, on engine block

(159) – Ground connection –2–, in Digifant Multipoint Fuel Injection (MFI) wiring harness

(G1) – Plus connection, in Digifant Multipoint Fuel Injection (MFI) wiring harness

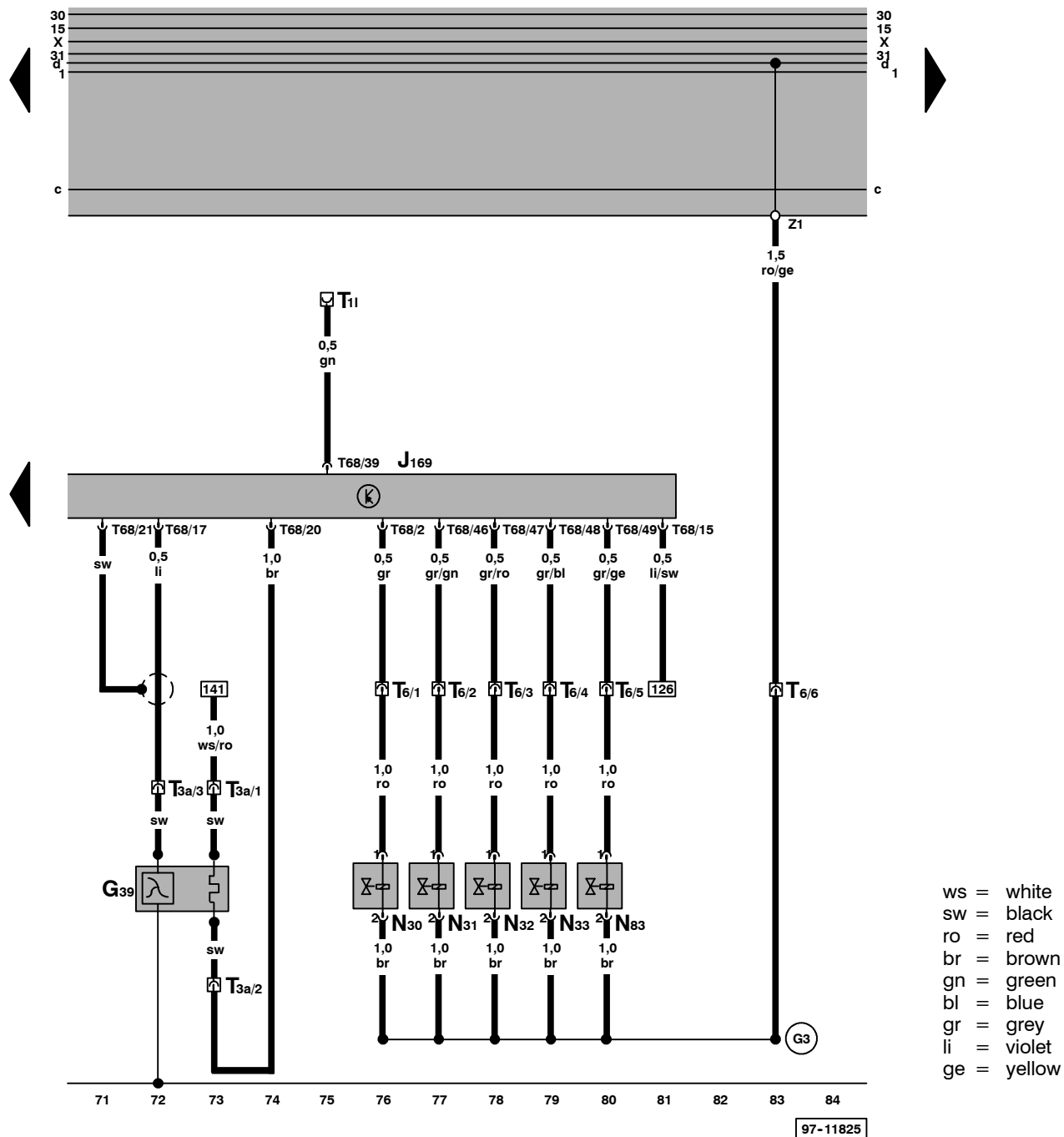

- G39 – Heated Oxygen Sensor (HO2S)
(00525–2342)
- J169 – Digifant Engine Control Module (ECM),
near battery
- N30 – Cylinder 1 Fuel Injector (01249–4411)
- N31 – Cylinder 2 Fuel Injector
- N32 – Cylinder 3 Fuel Injector
- N33 – Cylinder 4 Fuel Injector
- N83 – Cylinder 5 Fuel Injector
- T11 – Single Connector, behind fuse/relay panel,
(for A/C)
- T3a – 3-Pin Connector, near exhaust pipe
- T6 – 6-Pin Connector, in engine compartment,
right
- T68 – 68-Pin Connector

(G3) – Plus connection, in injector wiring harness

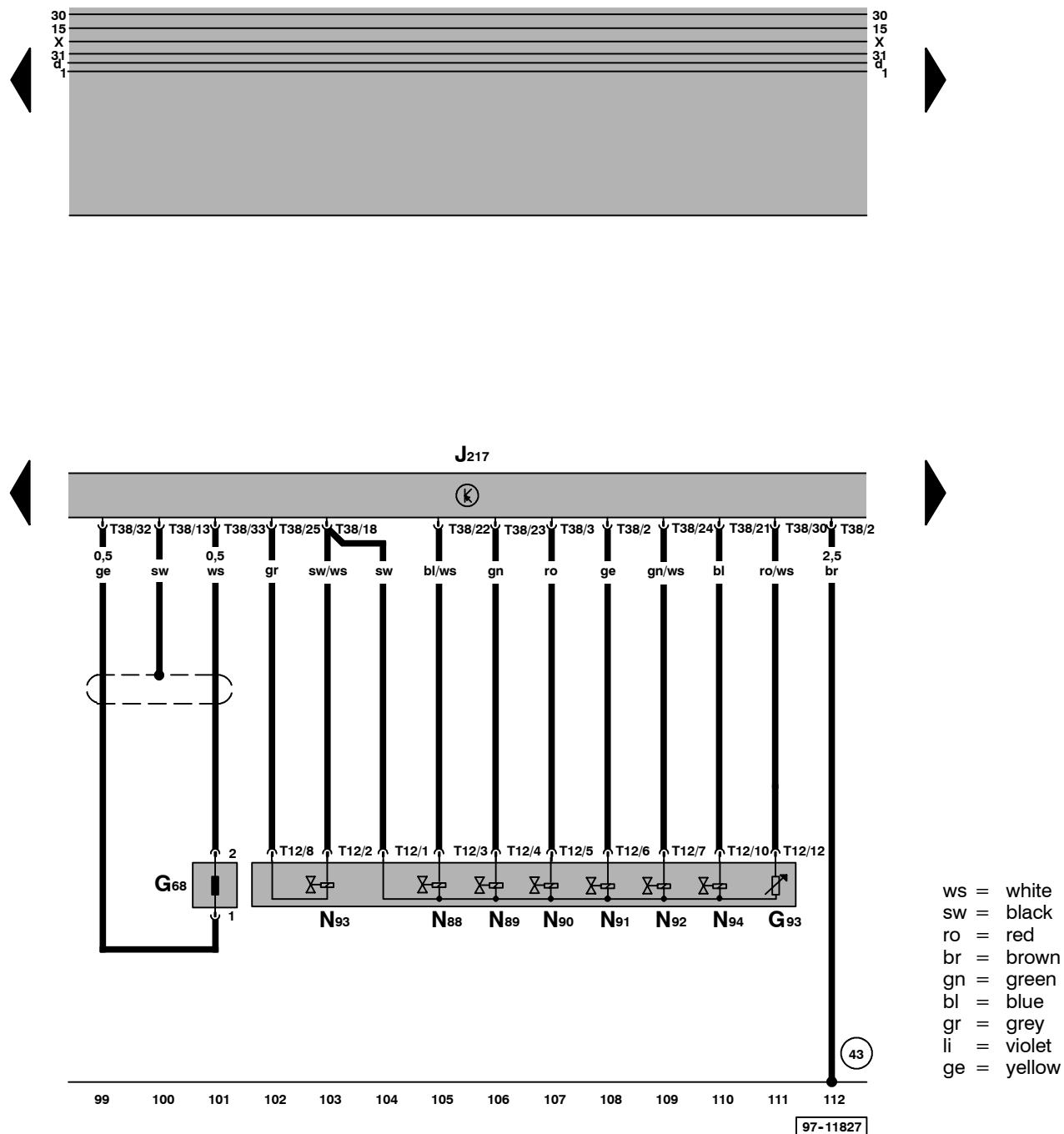

G68 – Vehicle Speed Sensor (VSS)
(00281 – 1231)

G93 – Transmission Fluid Temperature Sensor
(00300 – 1333)

J217 – Transmission Control Module (TCM), on
right A-pillar, lower part

N88 – Solenoid valve 1 (00258 – 1113)

N89 – Solenoid valve 2 (00260 – 1121)

N90 – Solenoid valve 3 (00262 – 1123)

N91 – Solenoid valve 4 (00264 – 1131)

N92 – Solenoid valve 5 (00266 – 1133)

N93 – Solenoid valve 6 (00268 – 1141)

N94 – Solenoid valve 7 (00270 – 1143)

T12 – 12-Pin Connector

T38 – 38-Pin Connector

43 – Ground connection, on right A-pillar, lower
part

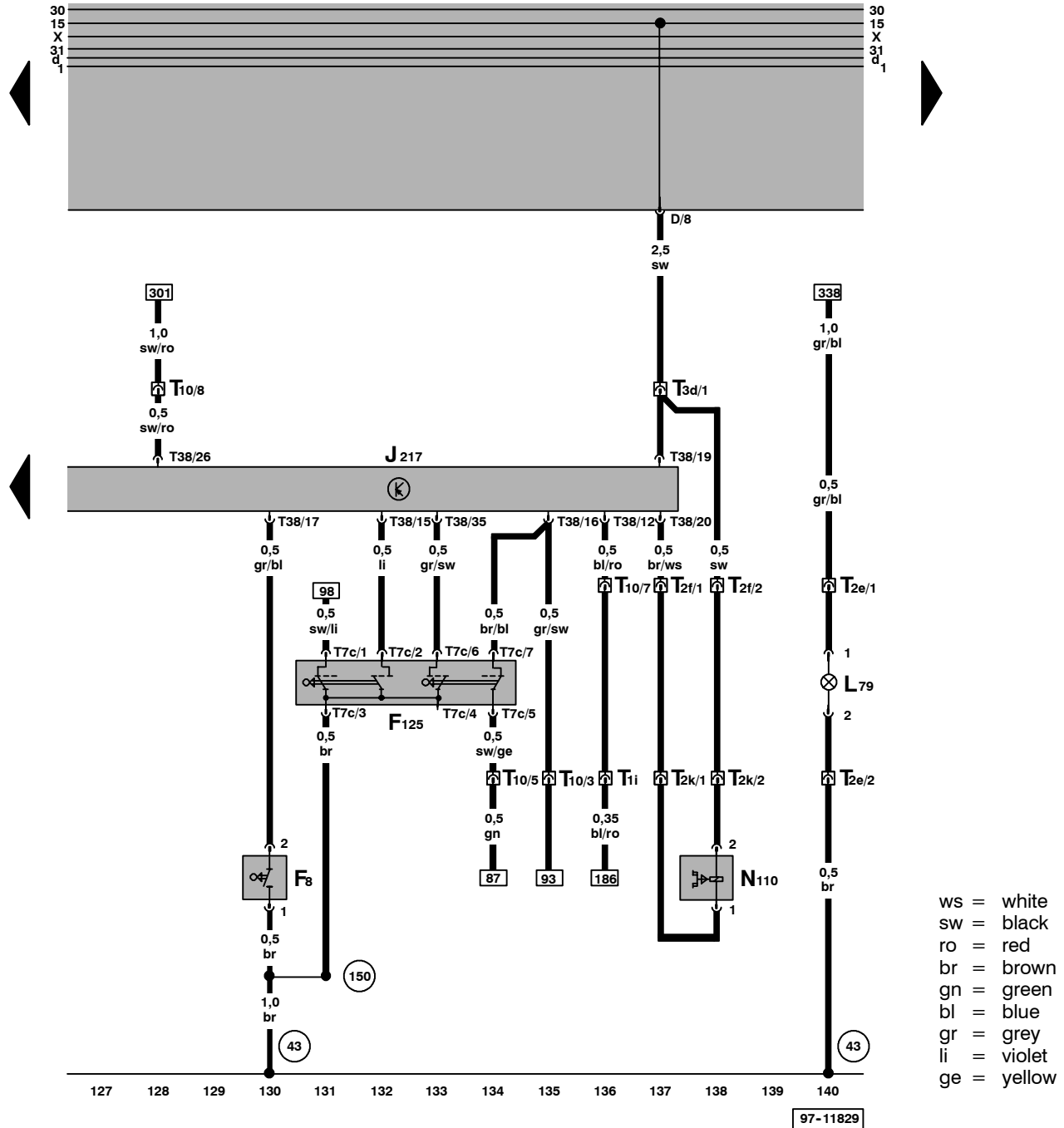

ws = white
 sw = black
 ro = red
 br = brown
 gn = green
 bl = blue
 gr = grey
 li = violet
 ge = yellow

- F8 – Kick Down Switch
- F125 – Multi-Function Transmission Range (TR) Switch (00293-1314)
- J217 – Transmission Control Module (TCM), on right A-pillar, lower part
- L79 – Selector Lever Light
- N110 – Shift Lock Solenoid (01236-4314)
- T1i – Single Connector, behind fuse/relay panel
- T2e – Double Connector, near selector lever
- T2f – Double Connector, behind instrument panel, right
- T2k – Double Connector, near selector lever
- T3d – 3-Pin Connector, behind instrument panel, right
- T7c – 7-Pin Connector

- T10 – 10-Pin Connector, behind instrument panel, right
- T38 – 38-Pin Connector
- (43) – Ground connection, on right A-pillar, lower part
- (150) – Ground connection, in automatic transmission wiring harness

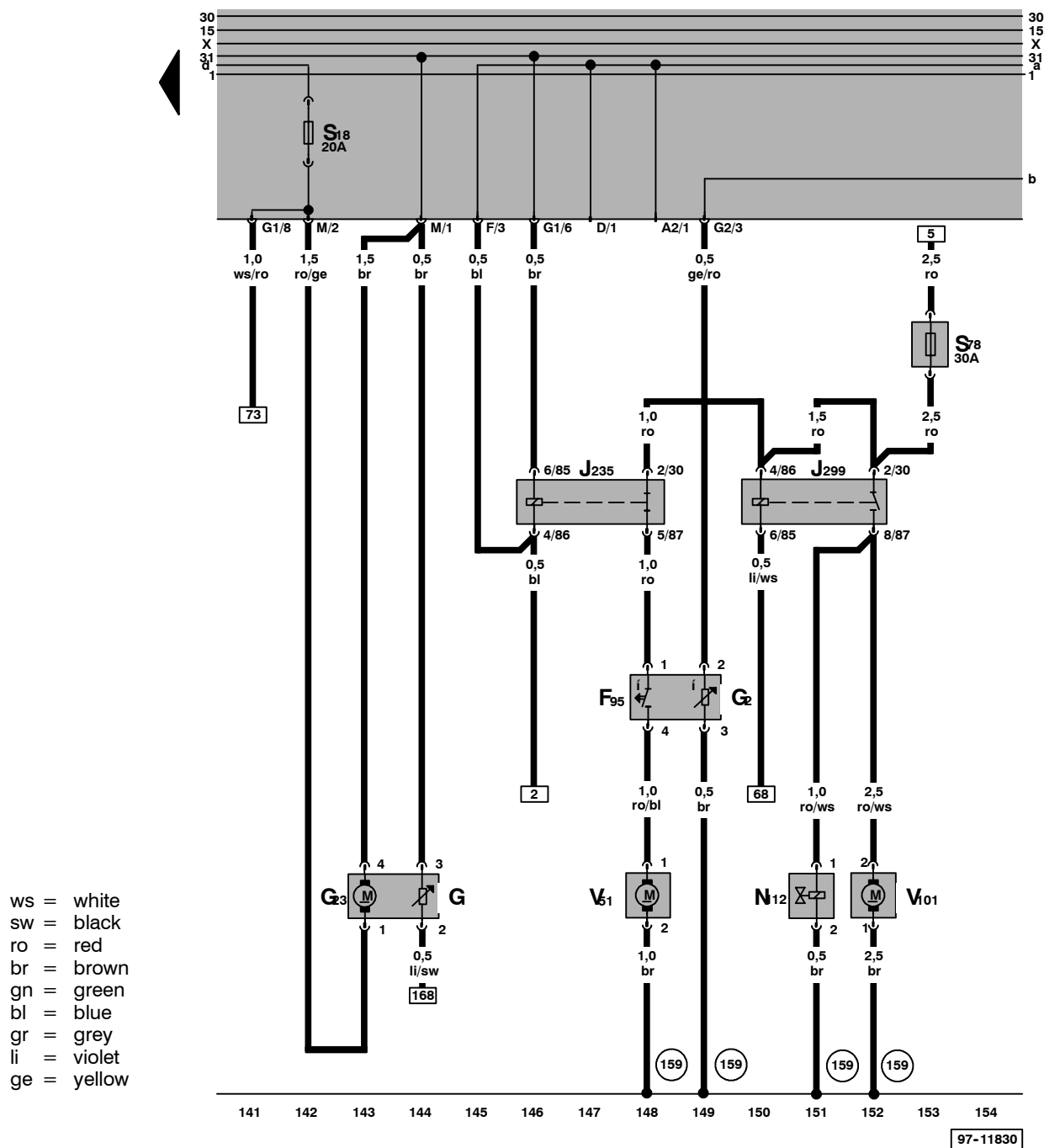

- F95 – After-Run Coolant Pump Thermal Switch
- G – Fuel Level Sensor
- G2 – Engine Coolant Temperature (ECT) Sensor
- G23 – Transfer Fuel Pump (FP)
- J235 – Engine Coolant Pump Relay, behind fuse/relay panel
- J299 – Secondary Air Injection (AIR) Pump Relay
- N112 – Secondary Air Injection (AIR) Solenoid Valve
- S78 – Engine Coolant Pump and Secondary Air Injection (AIR) Pump Motor Circuit Breaker, behind fuse/relay panel
- V51 – After-Run Coolant Pump
- V101 – Secondary Air Injection (AIR) Pump Motor
- (159) – Ground connection –2–, in Digifant Multi-Port Fuel Injection (MFI) wiring harness

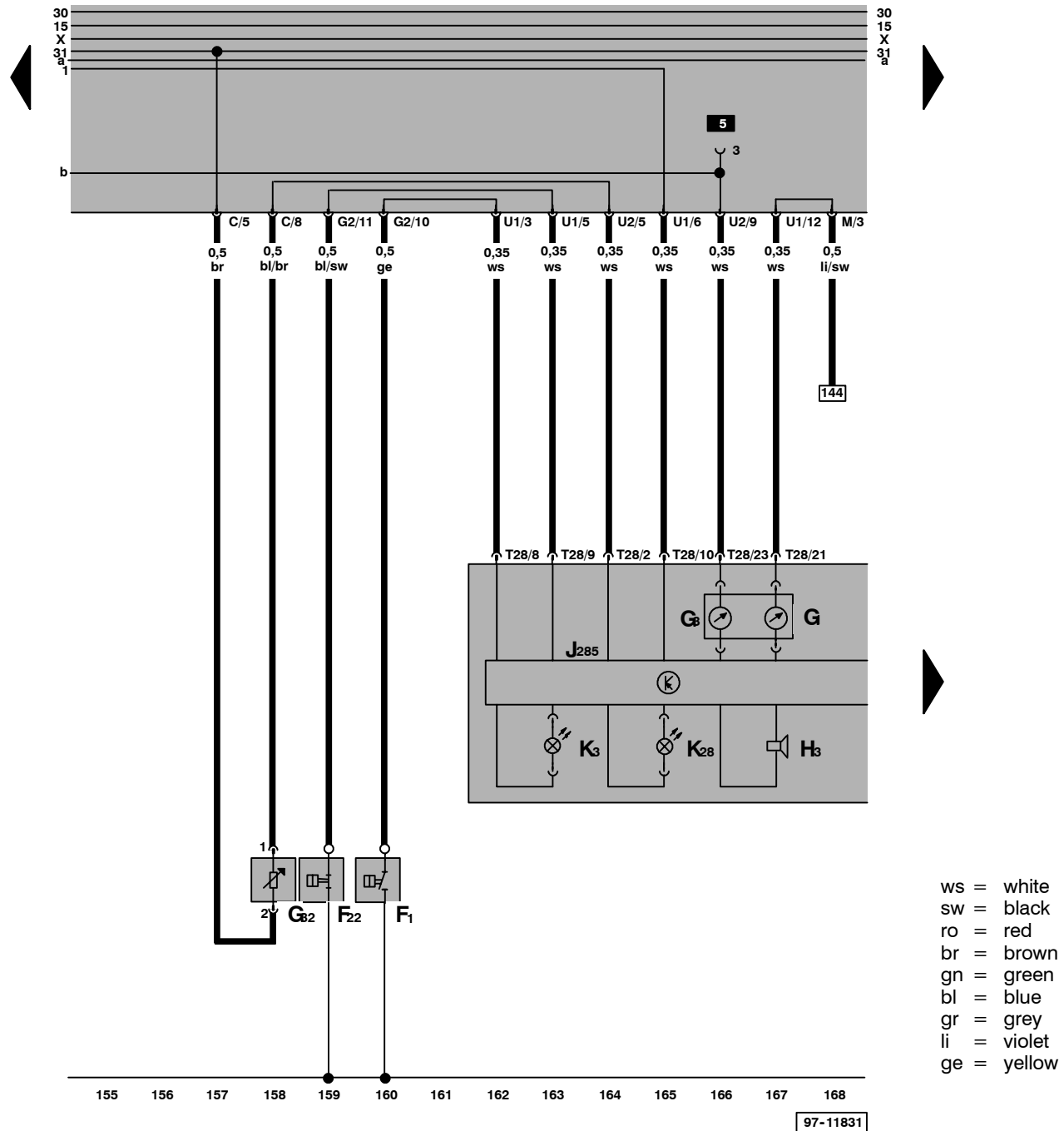

- F1 – Oil Pressure Switch
- F22 – 0.3 Bar Oil Pressure Switch
- G1 – Fuel Gauge
- G3 – Engine Coolant Temperature (ECT) Gauge
- G32 – Engine Coolant Level (ECL) Sensor
- H3 – Warning Buzzer
- J285 – Control Module With Display Unit In Instrument Cluster
- K3 – Oil Pressure Warning Light
- K28 – Engine Coolant Level/Temperature (ECL/ECT) Warning Light, on instrument cluster
- T28 – 28-Pin Connector

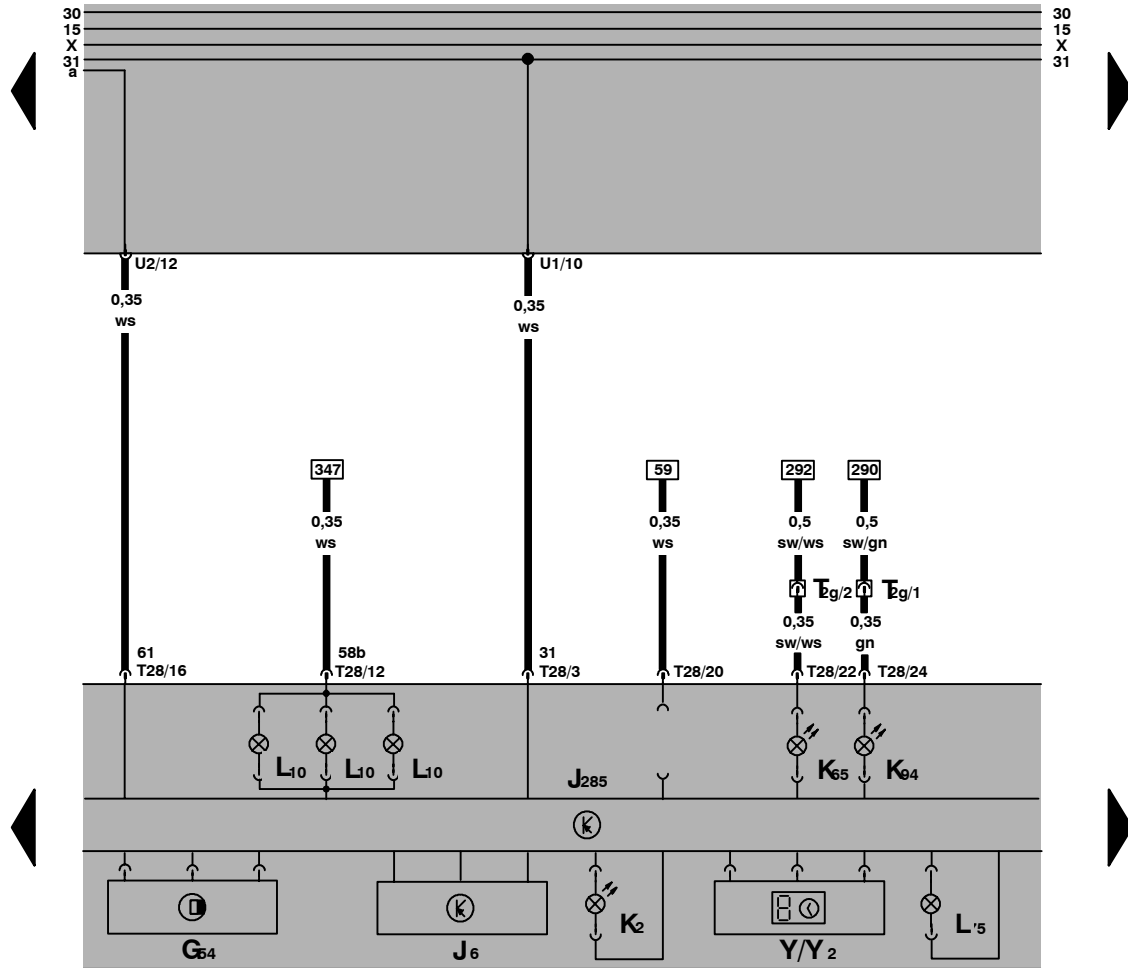

ws = white
 sw = black
 ro = red
 br = brown
 gn = green
 bl = blue
 gr = grey
 li = violet
 ge = yellow

169 170 171 172 173 174 175 176 177 178 179 180 181 182

97-11832

- G54 – Vehicle Speed Sensor (VSS)
- J6 – Voltage Stabilizer
- J285 – Control Module With Display Unit In Instrument Cluster
- K2 – Generator (GEN) Warning Light
- K65 – Left Turn Signal Indicator Light
- K94 – Right Turn Signal Indicator Light
- L10 – Instrument Cluster Light
- L75 – Digital Display Light
- T2g – Double Connector, behind fuse/relay panel
- T28 – 28-Pin Connector, on instrument cluster
- Y – Analog Clock
- Y2 – Digital Clock

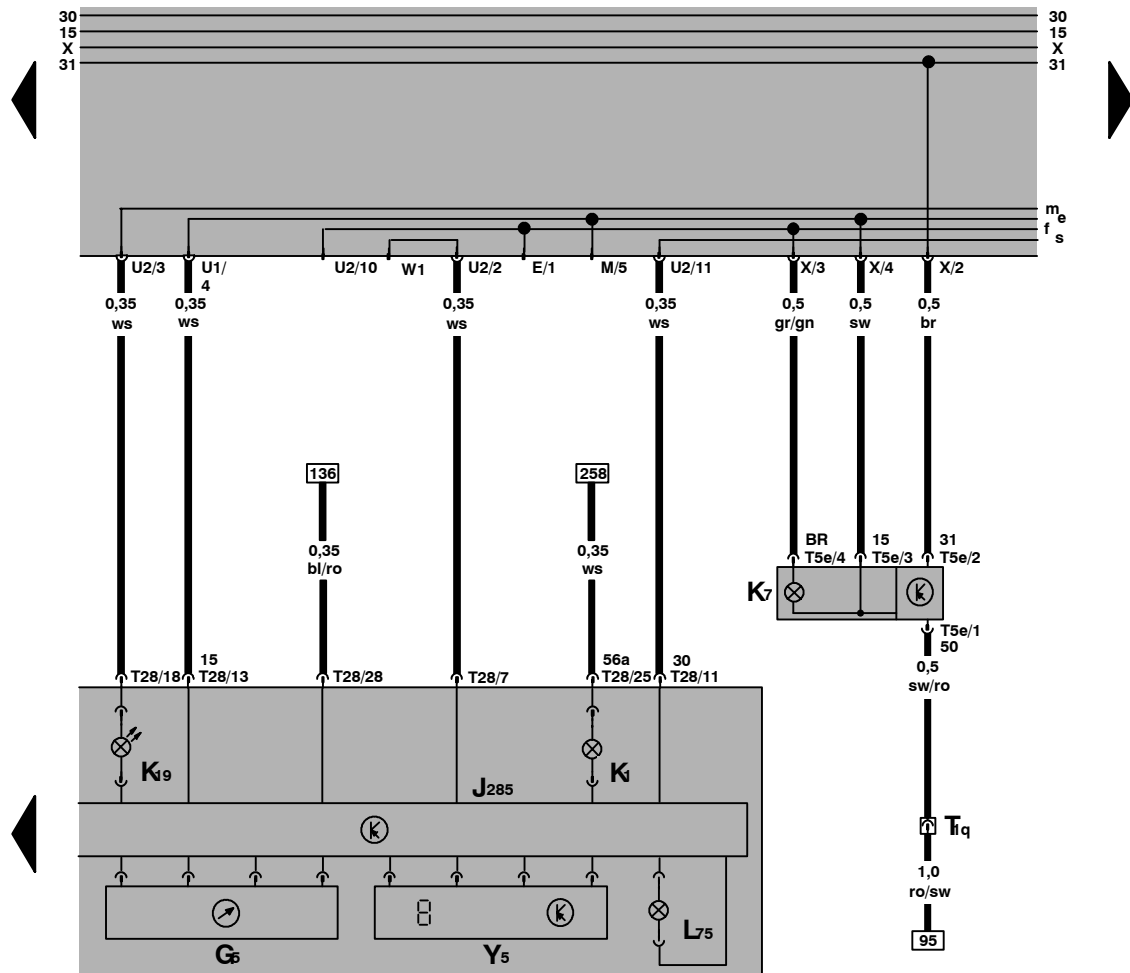

ws = white
 sw = black
 ro = red
 br = brown
 gn = green
 bl = blue
 gr = grey
 li = violet
 ge = yellow

183 184 185 186 187 188 189 190 191 192 193 194 195 196

97-11833

- G5 – Tachometer
- J285 – Control Module With Display Unit In Instrument Cluster
- K1 – Headlight High Beam Indicator Light
- K7 – Brake and Parking Brake Warning Light
- K19 – Seat Belt Warning Light
- L75 – Digital Display Light
- T1q – Single Connector, behind fuse/relay panel
- T5e – 5-Pin Connector
- T28 – 28-Pin Connector, on instrument cluster
- Y5 – Transmission Range (TR) Selector Lever Display

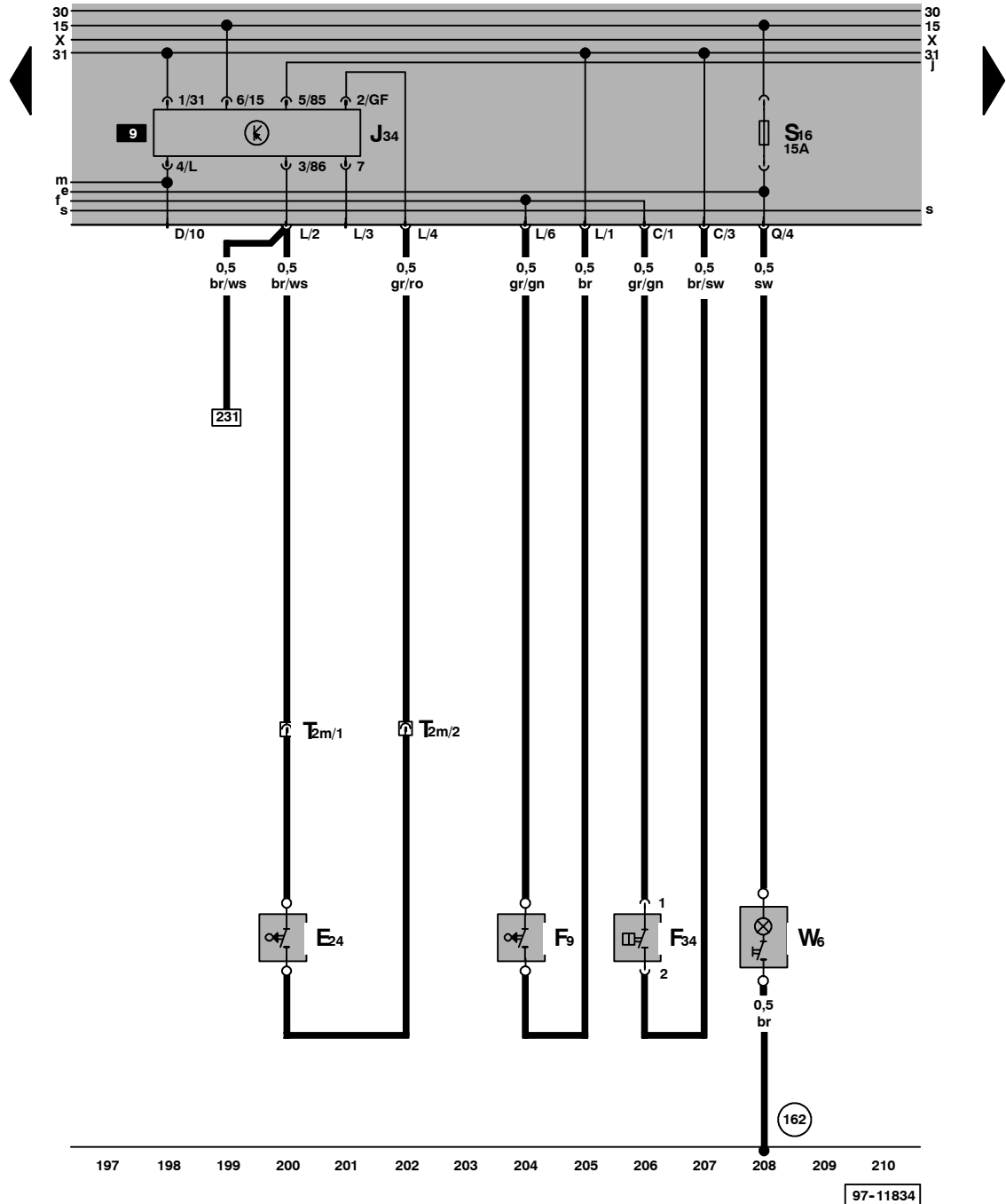

ws = white
 sw = black
 ro = red
 br = brown
 gn = green
 bl = blue
 gr = grey
 li = violet
 ge = yellow

- E24 – Left Seat Belt Switch
- F9 – Parking Brake Warning Light Switch
- F34 – Brake Fluid Level Warning Switch
- J34 – Seat Belt Warning System Relay
- T2m – Double Connector, near seat belt switch
- W6 – Glove Compartment Light

162 – Ground connection, in blower motor wiring harness

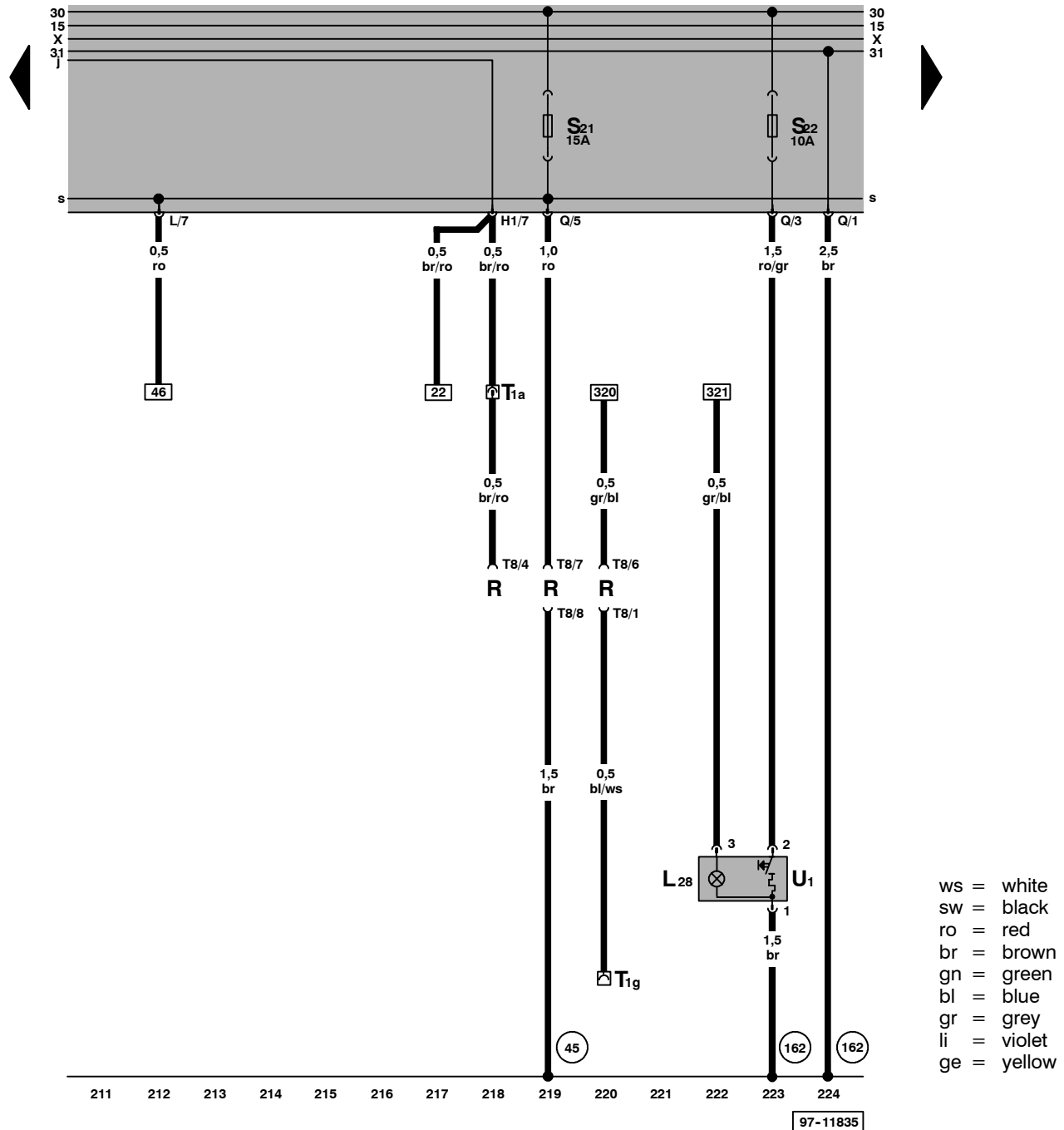

- L28 – Cigarette Lighter Light
- R – Radio
- T1a – Single Connector, behind fuse/relay panel
- T1g – Single connector, behind fuse/relay panel (Radio with GALA)
- T8 – 8-Pin Connector
- U1 – Cigarette Lighter
- (45) – Ground connection, behind instrument panel, center
- (162) – Ground connection, in blower motor wiring harness

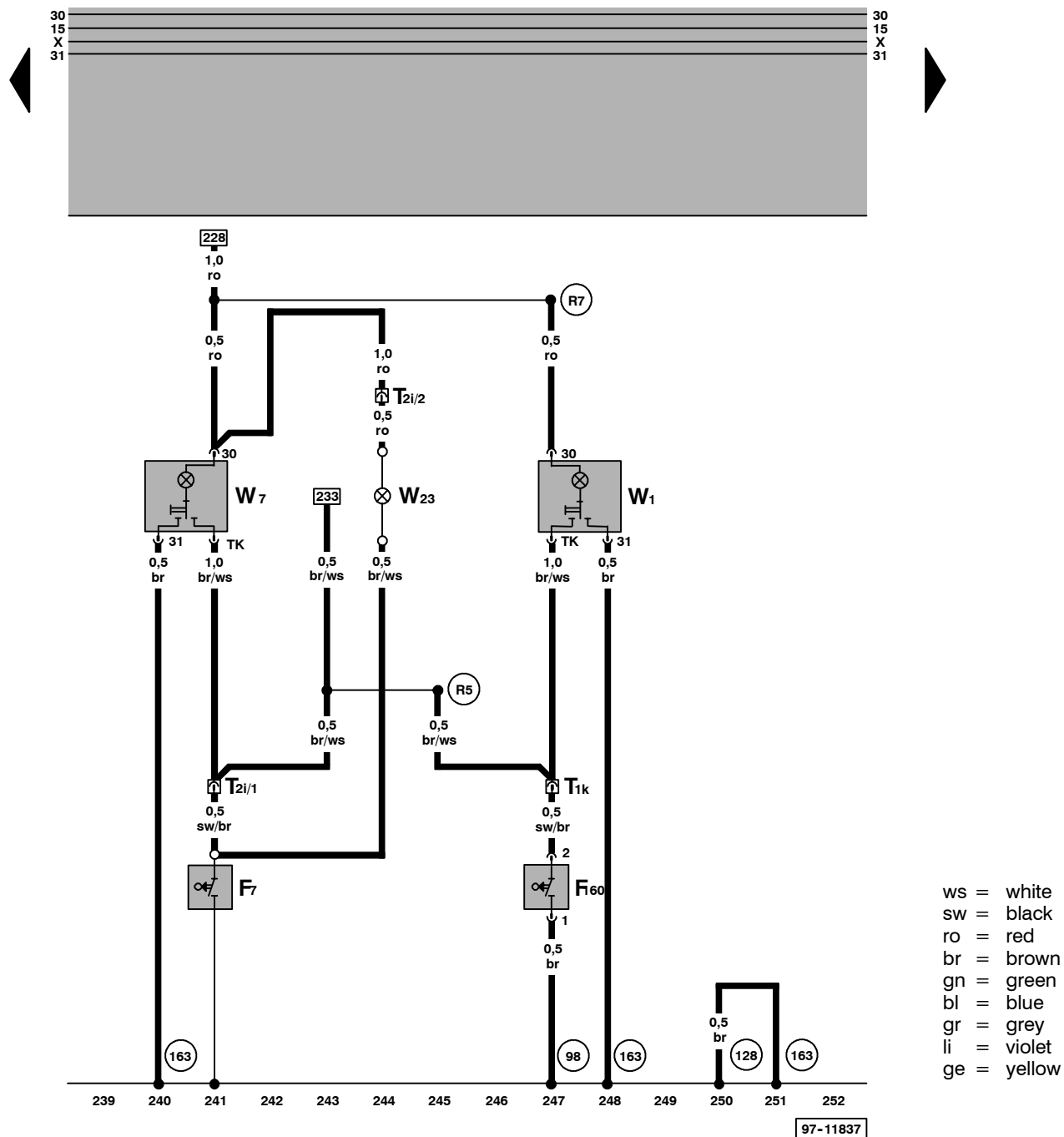

ws = white
 sw = black
 ro = red
 br = brown
 gn = green
 bl = blue
 gr = grey
 li = violet
 ge = yellow

- F7 – Right Rear Side/Sliding Door Contact Switch
- F160 – Rear Lid Contact Switch
- T1k – Single Connector, near tail light, right
- T2i – Double Connector, near interior light, center
- W1 – Rear/Luggage Compartment Interior Light
- W7 – Center Interior Light
- W23 – Footwell Light With Delay Switch

- (163) – Ground connection –2–, in interior light wiring harness
- (R5) – Wire connection –2–, in interior light wiring harness
- (R7) – Plus connection –2–, in interior light wiring harness

(98) – Ground connection, in rear lid wiring harness

(128) – Ground connection –1–, in interior light wiring harness

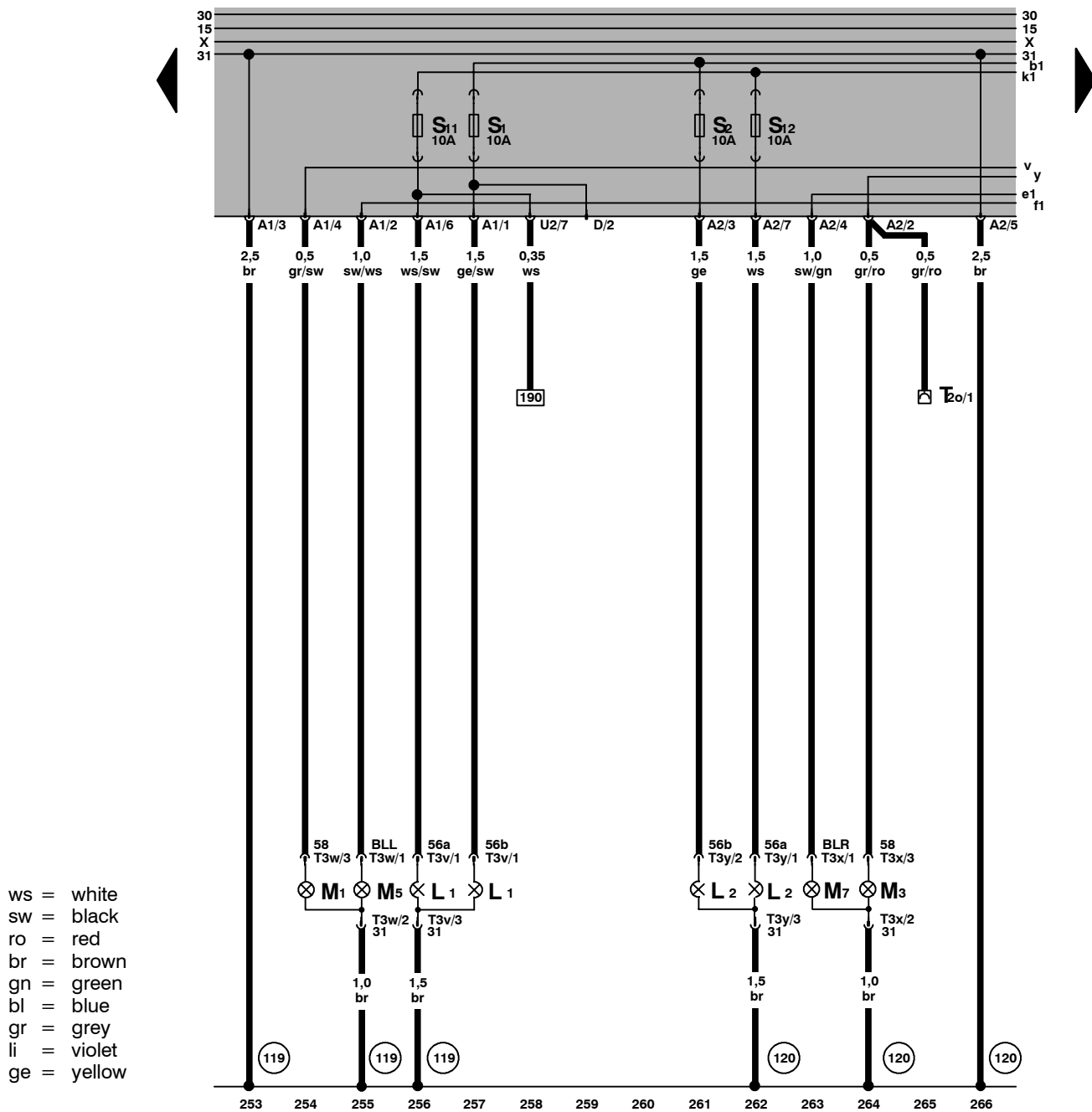

- ws = white
- sw = black
- ro = red
- br = brown
- gn = green
- bl = blue
- gr = grey
- li = violet
- ge = yellow

- L1 – Left Headlight
- L2 – Right Headlight
- M1 – Left Parking Light
- M3 – Right Parking Light
- M5 – Left Front Turn Signal Light
- M7 – Right Front Turn Signal Light
- T2o – Double Connector, near battery
- T3v – 3-Pin Connector
- T3w – 3-Pin Connector
- T3x – 3-Pin Connector
- T3y – 3-Pin Connector

(119) – Ground connection –1–, in headlight wiring harness

(120) – Ground connection –2–, in headlight wiring harness

97-11838

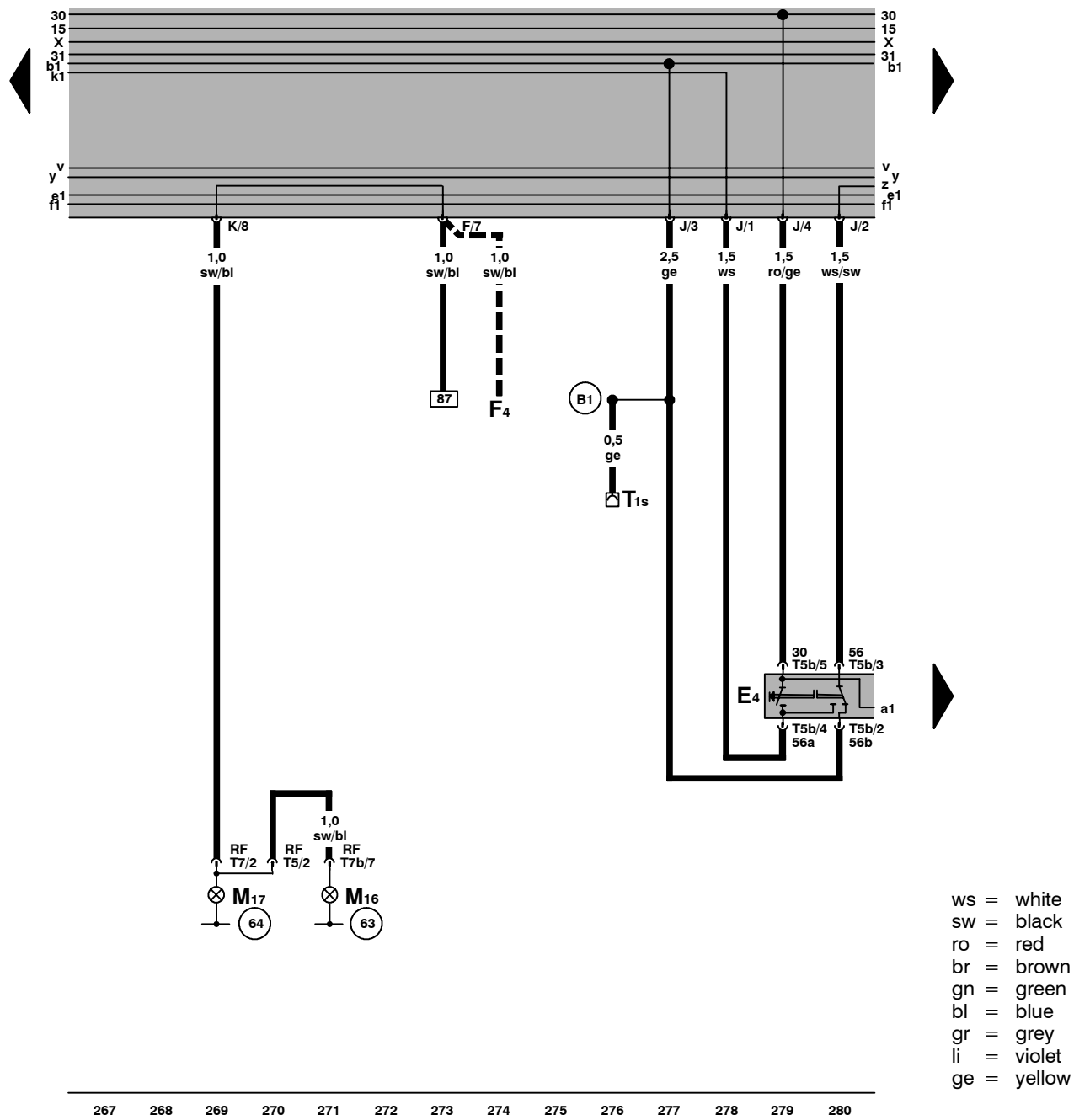

- E4 – Headlight Dimmer/Flasher Switch
- F4 – Back-Up Light Switch
- M16 – Left Back-Up Light
- M17 – Right Back-Up Light
- T1s – Single Connector, behind fuse/relay panel
- T5 – 5-Pin Connector, on tail light, right
- T5b – 5-Pin Connector, behind steering column switch cover
- T7 – 7-Pin Connector, on tail light, right
- T7b – 7-Pin Connector, on tail light, left
- (63) – Ground connection, on left tail light bulb holder
- (64) – Ground connection, on right tail light bulb holder

- (B1) – Wire connection (56 b), in steering column switch wiring harness
- — Manual transmission only

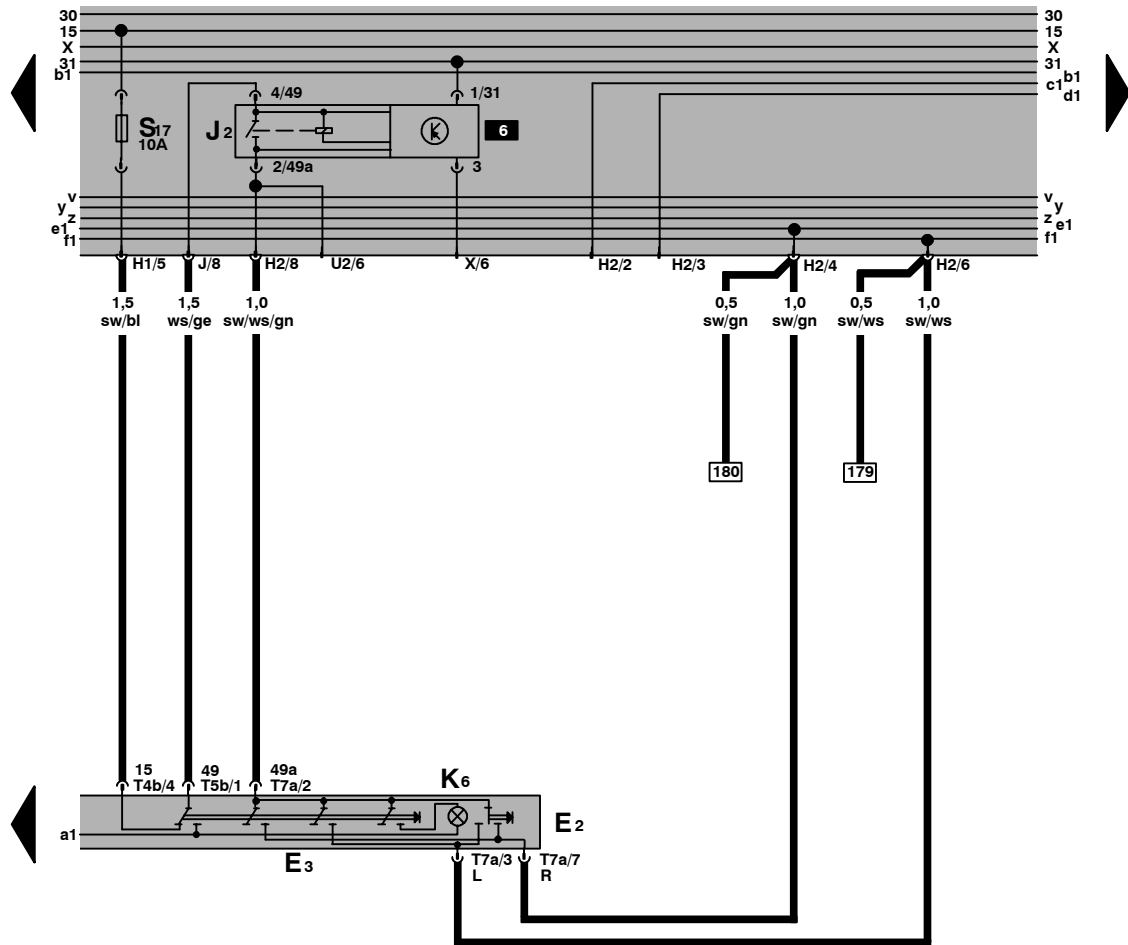

- ws = white
- sw = black
- ro = red
- br = brown
- gn = green
- bl = blue
- gr = grey
- li = violet
- ge = yellow

281 282 283 284 285 286 287 288 289 290 291 292 293 294

97-11840

- E2 – Turn Signal Switch
- E3 – Emergency Flasher Switch
- J2 – Emergency Flasher Relay
- K6 – Emergency Flasher Warning Light
- T4b – 4-Pin Connector, behind steering column switch cover
- T5b – 5-Pin Connector, behind steering column switch cover
- T7a – 7-Pin Connector, behind steering column switch cover

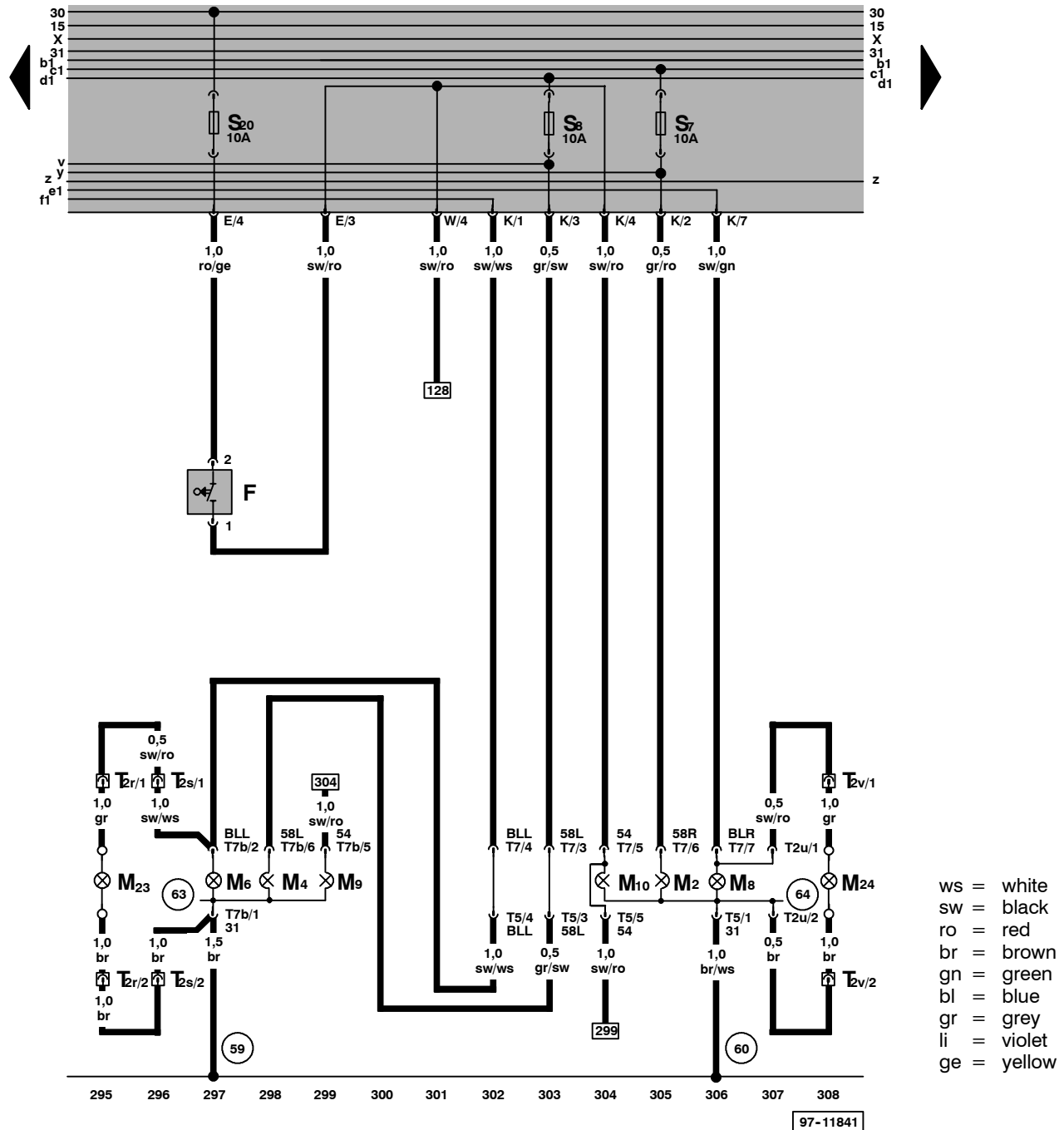

- F – Brake Light Switch
- M2 – Right Tail Light
- M4 – Left Tail Light
- M6 – Left Rear Turn Signal Light
- M8 – Right Rear Turn Signal Light
- M9 – Left Brake Light
- M10 – Right Brake Light
- M23 – Left Roof Turn Signal Light
- M24 – Right Roof Turn Signal Light
- T2r – Double Connector, near roof turn signal, left
- T2s – Double Connector, near tail light, left
- T2u – Double Connector, near tail light, right
- T2v – Double Connector, near roof turn signal, right
- T5 – 5-Pin Connector
- T7 – 7-Pin Connector
- T7b – 7-Pin connector

- 59 – Ground connection, near tail light, left
- 60 – Ground connection, near tail light, right
- 63 – Ground connection, on left tail light bulb-holder
- 64 – Ground connection, on right tail light bulb holder

* – Different wire routing for flatbed vehicles

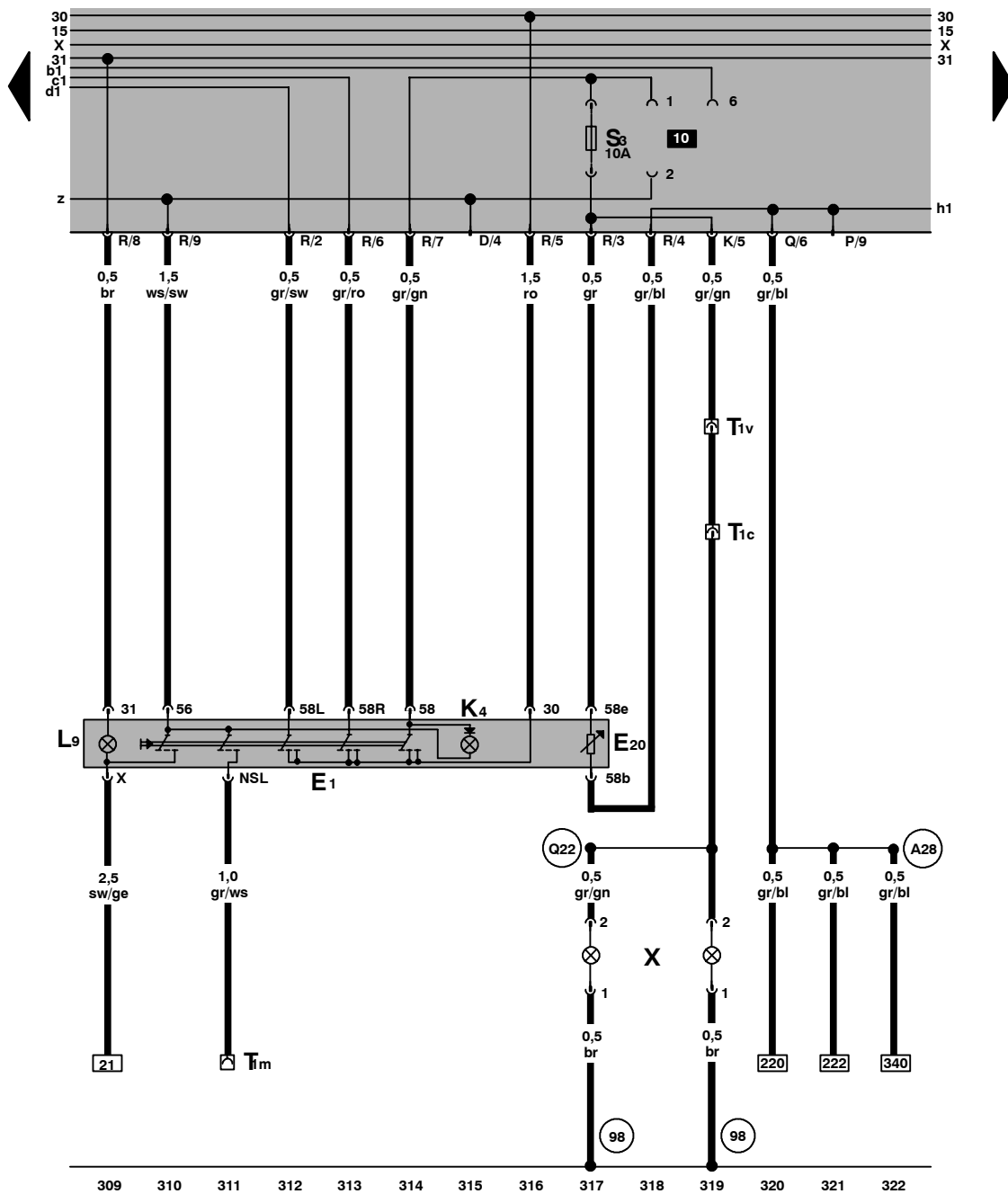

ws = white
 sw = black
 ro = red
 br = brown
 gn = green
 bl = blue
 gr = grey
 li = violet
 ge = yellow

97-11842

- E1 – Light Switch
- E20 – Instrument Panel Light Dimmer Switch
- K4 – Park Light Indicator Light
- L9 – Headlight Switch Light
- T1c – Single Connector, near tail light, right
- T1m – Single Connector, behind fuse/relay panel
- T1v – Single Connector, near tail light, left
- X – License Plate Light

98 – Ground connection, in rear lid wiring harness

A28 – Plus connection (58b), in fresh air blower wiring harness

Q22 – Wire connection –1–, in rear lid wiring

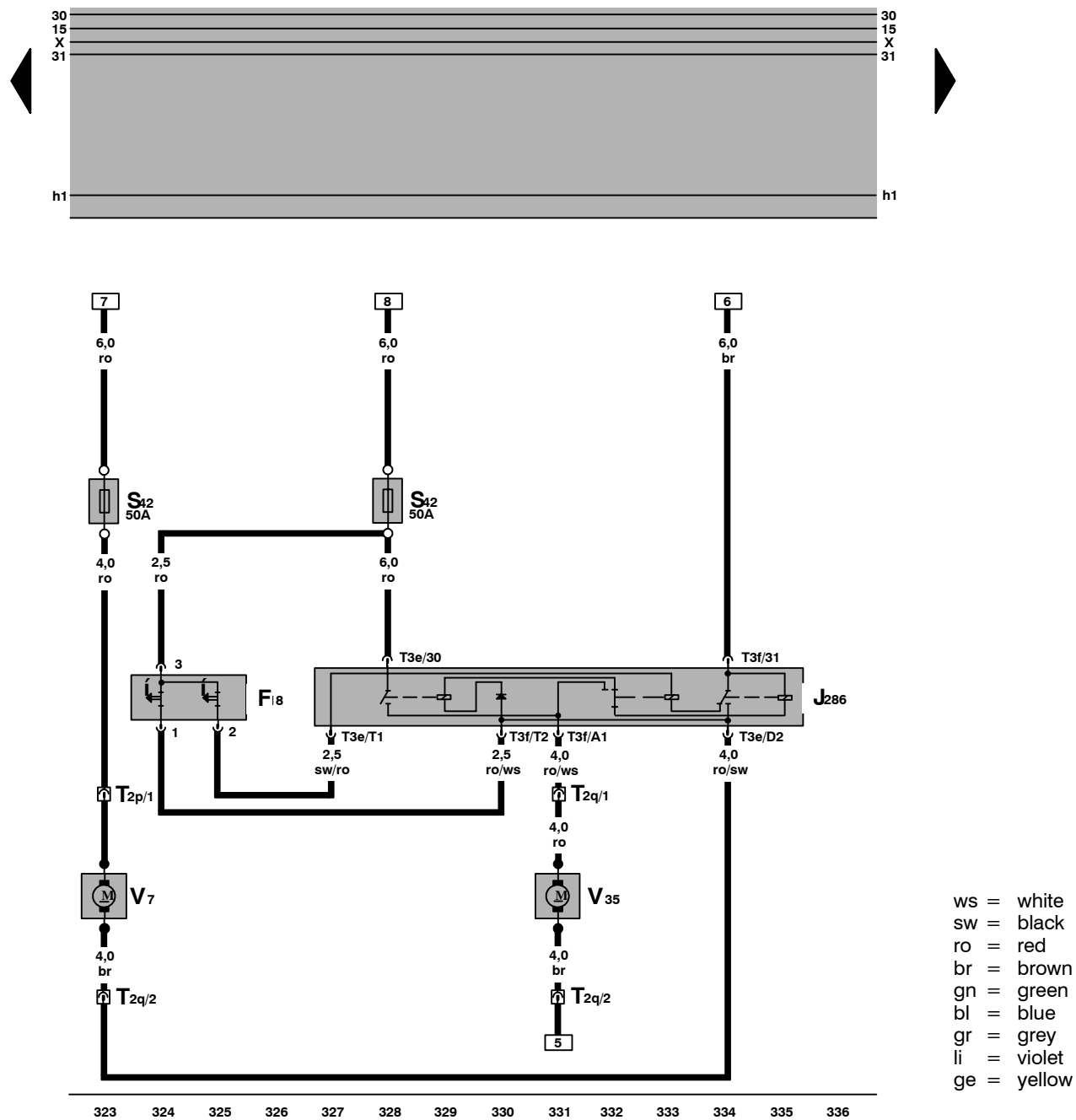

97-11843

- F18 – Coolant Fan Control (FC) Thermal Switch
- J286 – Series/Parallel Coolant Fan Control (FC) Relay (V7, V35)
- S42 – Coolant Fan Fuse, near fan
- T2p – Double Connector, in engine compartment, front
- T2g – Double Connector, in engine compartment, front
- T3e – 3-Pin Connector
- T3f – 3-Pin Connector
- V7 – Coolant Fan
- V35 – Right Coolant Fan

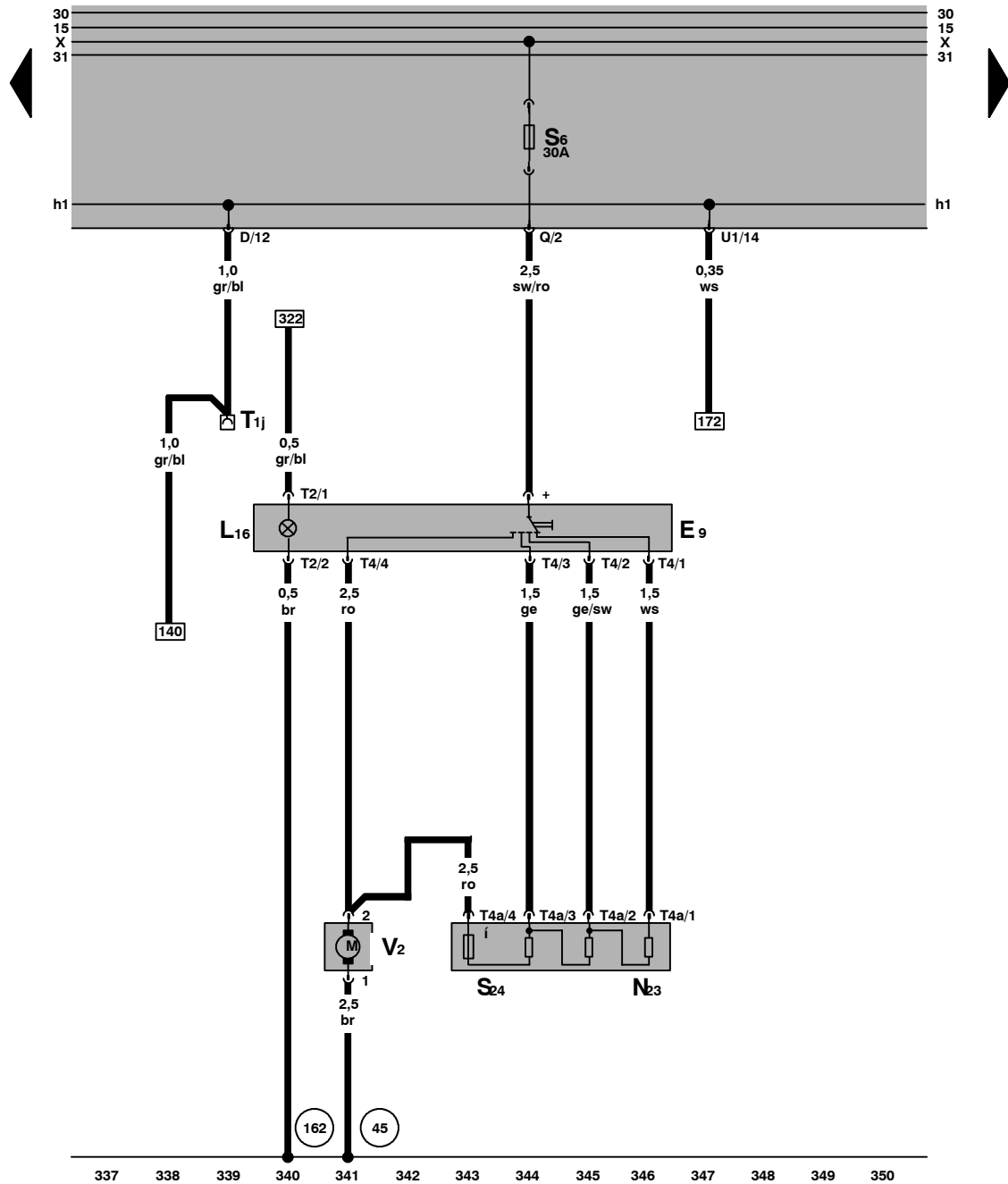

- ws = white
- sw = black
- ro = red
- br = brown
- gn = green
- bl = blue
- gr = grey
- li = violet
- ge = yellow

97-11844

- E9 – Fresh Air Blower Switch
- L16 – Fresh Air Control Lever Light
- N23 – Fresh Air Blower Series Resistance
- S24 – Heater, A/C Clutch Fuse
- T1j – Single Connector, behind fuse/relay panel
- T2 – Double Connector
- T4 – 4-Pin Connector
- T4a – 4-Pin Connector
- V2 – Fresh Air Blower

- (45) – Ground connection, behind instrument panel, center
- (162) – Ground connection, in blower motor wiring harness

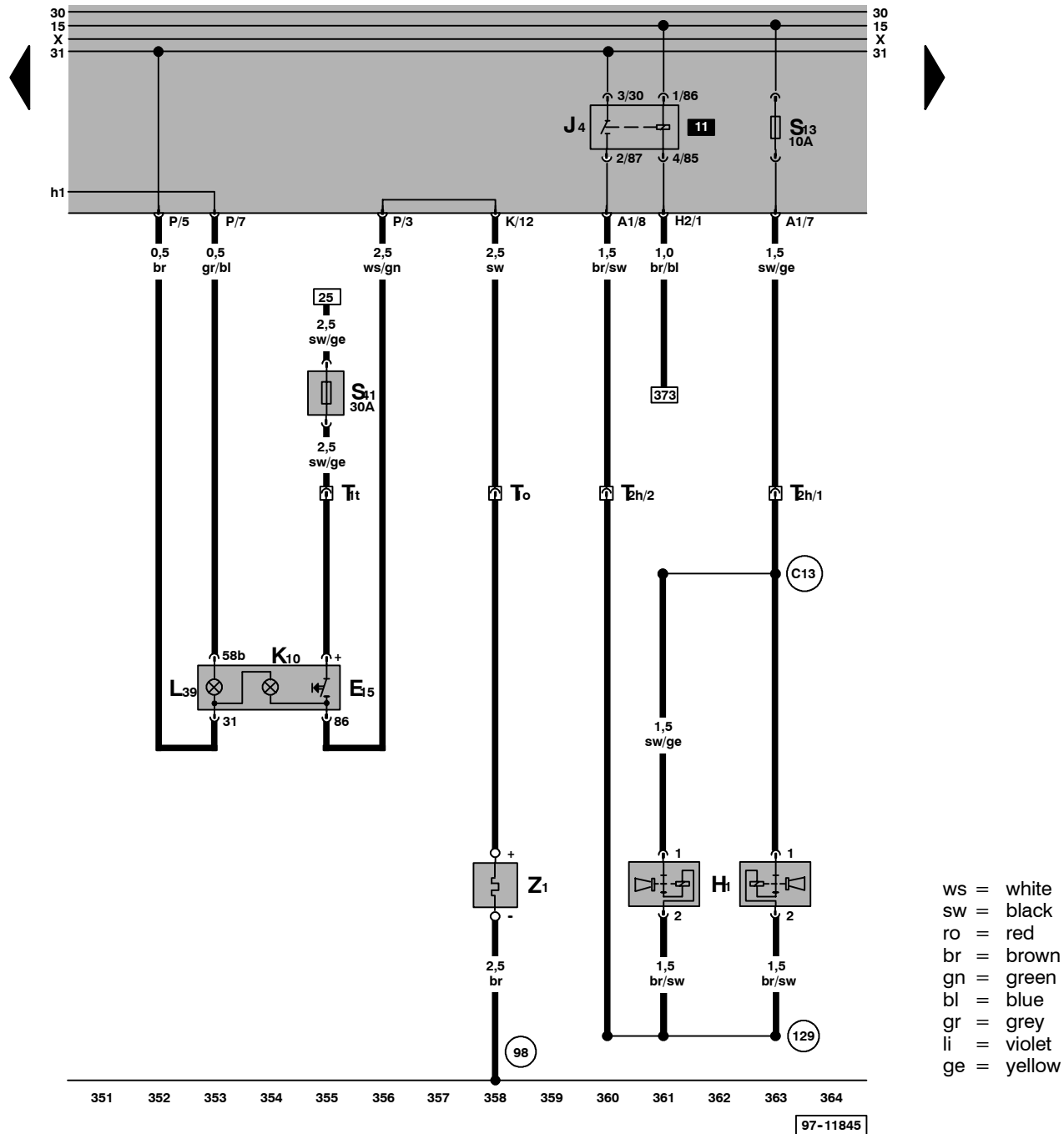

- E15 – Rear Window Defogger Switch
- H1 – Dual Horns
- J4 – Dual Horn Relay
- K10 – Rear Window Defogger Indicator Light
- L39 – Rear Window Defogger Switch Light
- S41 – Rear Window Defogger Fuse, above fuse relay panel
- T1o – Single Connector, near tail light, right
- T1t – Single Connector, behind fuse/relay panel
- T2h – Double Connector, in engine compartment, left front
- Z1 – Rear Window Defogger/Heat Element

(129) – Ground connection, in dual-tone horn wiring harness

(C13) – Plus connection, in dual-tone horn wiring harness

(98) – Ground connection, in rear lid wiring harness

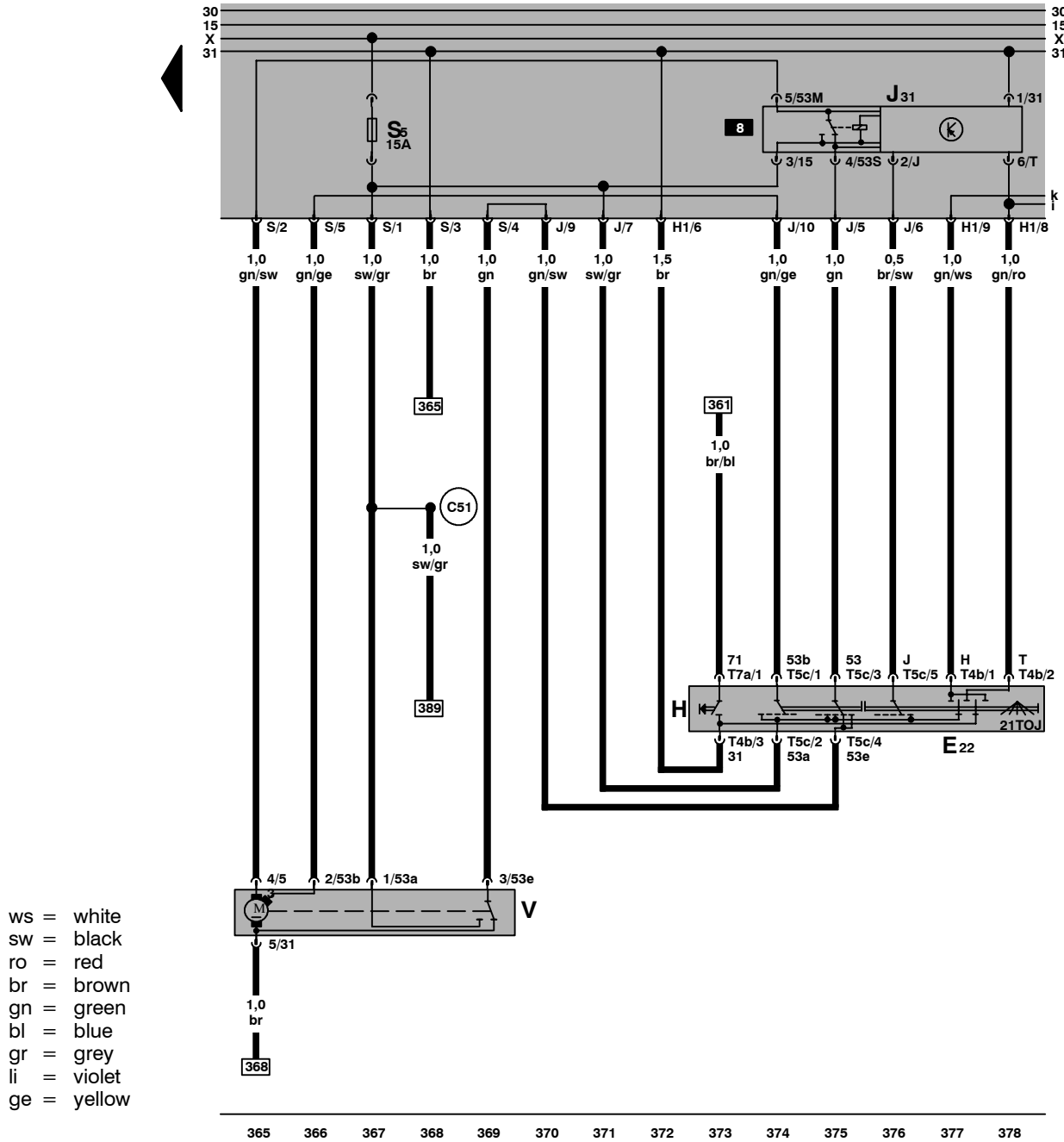

- ws = white
- sw = black
- ro = red
- br = brown
- gn = green
- bl = blue
- gr = grey
- li = violet
- ge = yellow

97-11846

- E22 – Windshield Wiper/Washer Switch
- H – Horn Button
- J31 – Wiper/Washer Intermittent Relay
- T4b – 4-Pin Connector
- T5c – 5-Pin Connector
- T7a – 7-Pin Connector
- V – Windshield Wiper Motor

(C51) – Plus connection (x), in wiper motor wiring harness

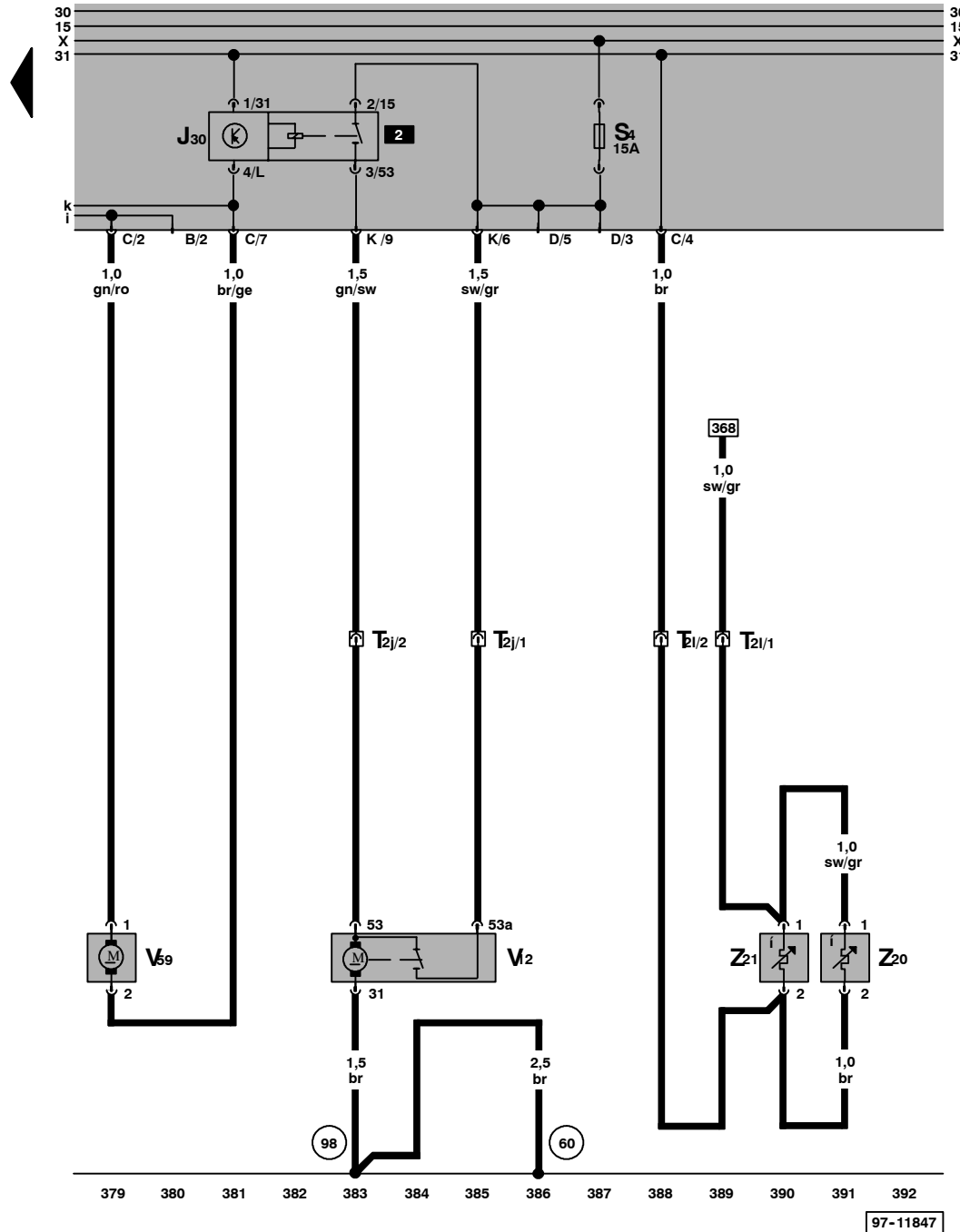

ws = white
 sw = black
 ro = red
 br = brown
 gn = green
 bl = blue
 gr = grey
 li = violet
 ge = yellow

- J30 – Rear Window Wiper/Washer Relay
- T2j – Double Connector, near tail light, right
- T2l – Double Connector, near firewall, right
- V12 – Rear Window Wiper Motor
- V59 – Windshield and Rear Window Washer Pump
- Z20 – Left Washer Nozzle Heater
- Z21 – Right Washer Nozzle Heater

60 – Ground connection, near tail light, right

98 – Ground connection, in rear lid wiring harness